



Hangers for the installation of HELIFLEX® cables on different supporting profiles.  
 Cable Clamp and Extended Counterbed hot-galvanized steel  
 Screw: stainless steel.

**FEATURES / BENEFITS**



picture shows the 1L4 version for illustration purpose only

**Technical features**

**GENERAL SPECIFICATIONS**

Product Line		Coaxial Cable Accessories
Product Type		Hanger
Hanger Type		Anchor bar 18-22mm (0.71-0.87")
Transmission Line Type		HCA495
Cable Type		Air Dielectric

**MECHANICAL SPECIFICATIONS**

Cable Size		5
Material		Cable Clamp : hot-dip galvanized Extended Counterbed : hot-dip galvanized Screw: Stainless steel
Recommended / Maximum Clamp Spacing	m (ft)	1 / 2 (3.3 / 6.6)

**TEMPERATURE SPECIFICATIONS**

Operation Temperature	°C (°F)	-50 to 85 (-58 to 185 )
Storage Temperature	°C (°F)	-50 to 85 (-58 to 185 )

**PACKAGING INFORMATION**

Package Quantity		1
------------------	--	---

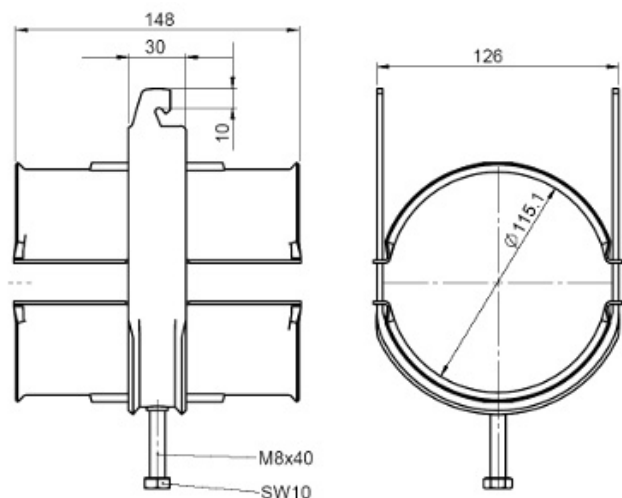



**HCH Clamps available for different types of interfaces:**

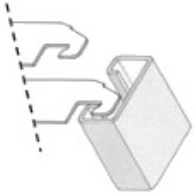

**Type C**  
For anchor bar  
(18-22mm slot)



**Type L**  
For angle iron  
(in different sizes)

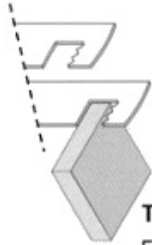

**Type R**  
For flat iron  
(6 – 12 mm)

[External Document Links](#)

[Notes](#)

Hangers for anchor bar 18-22 mm (0.71-0.87")